

PARTS LIST				
ITEM	QTY	PART NUMBER	MATERIAL	DESCRIPTION
1	1	BRACKET	7075-T6 ALUMINUM	DRILL PRESS BRACKET

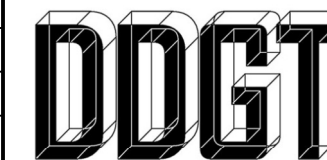

DIGITAL DESIGN
GRAPHICS
TECHNOLOGY

WWW.DDGT.NET

GENERAL NOTES:
FILLETS & ROUNDS R1/8
UNLESS OTHERWISE
SPECIFIED

#5-40 UNC-2B REQUIRES
4 HOLES EQUALLY
SPACED

BRACKET REQUIRES 2X
.20 DIAM. HOLES
DRILLED THROUGH

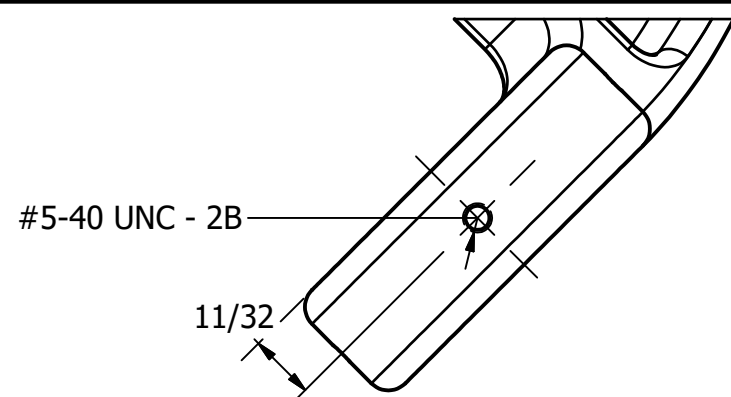

DRILL PRESS BRACKET
AUXILIARY VIEW
SCALE 1 : 1

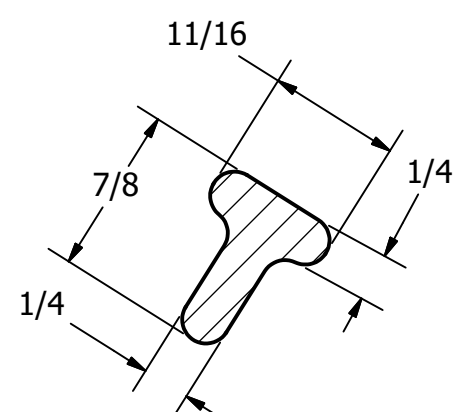

SECTION A-A
SCALE 1 : 1

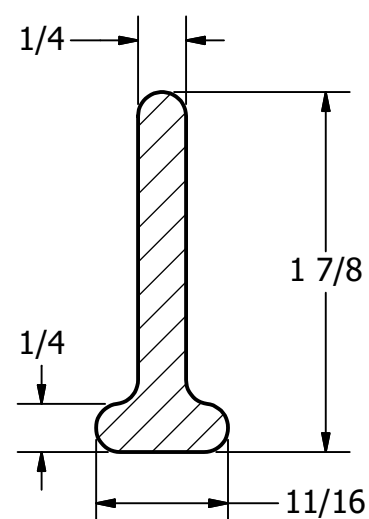

SECTION B-B
SCALE 1 : 1

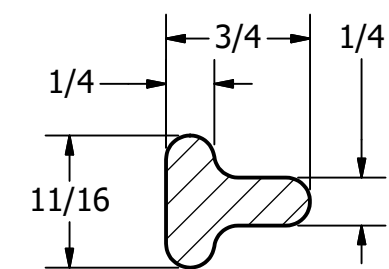

SECTION C-C
SCALE 1 : 1

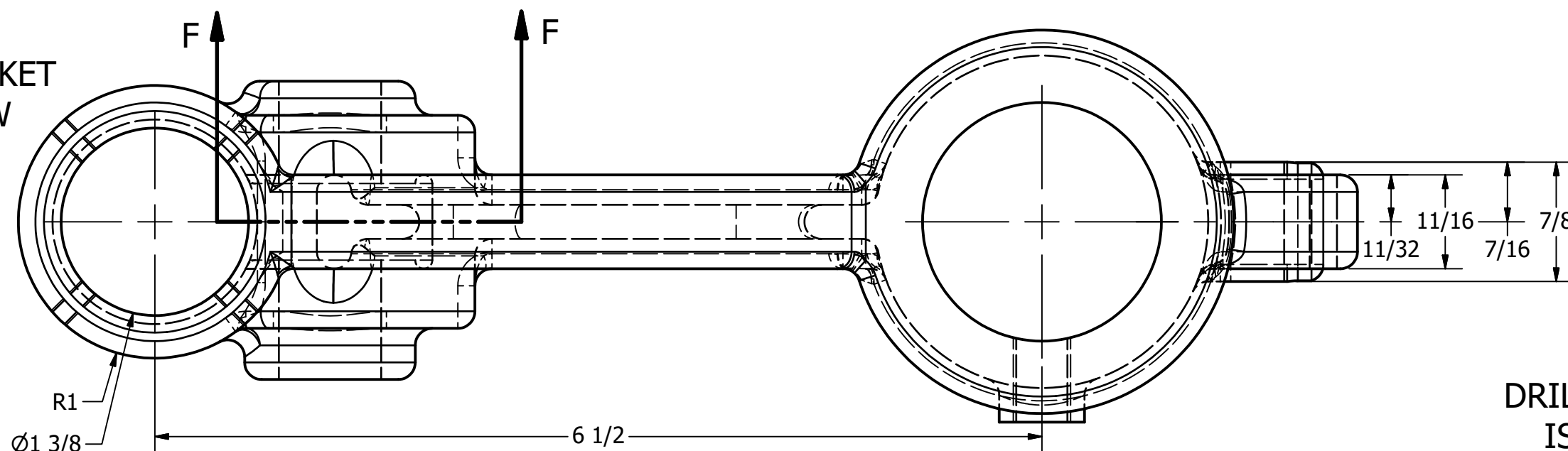

DRILL PRESS BRACKET (TOP)
SCALE 1 : 1

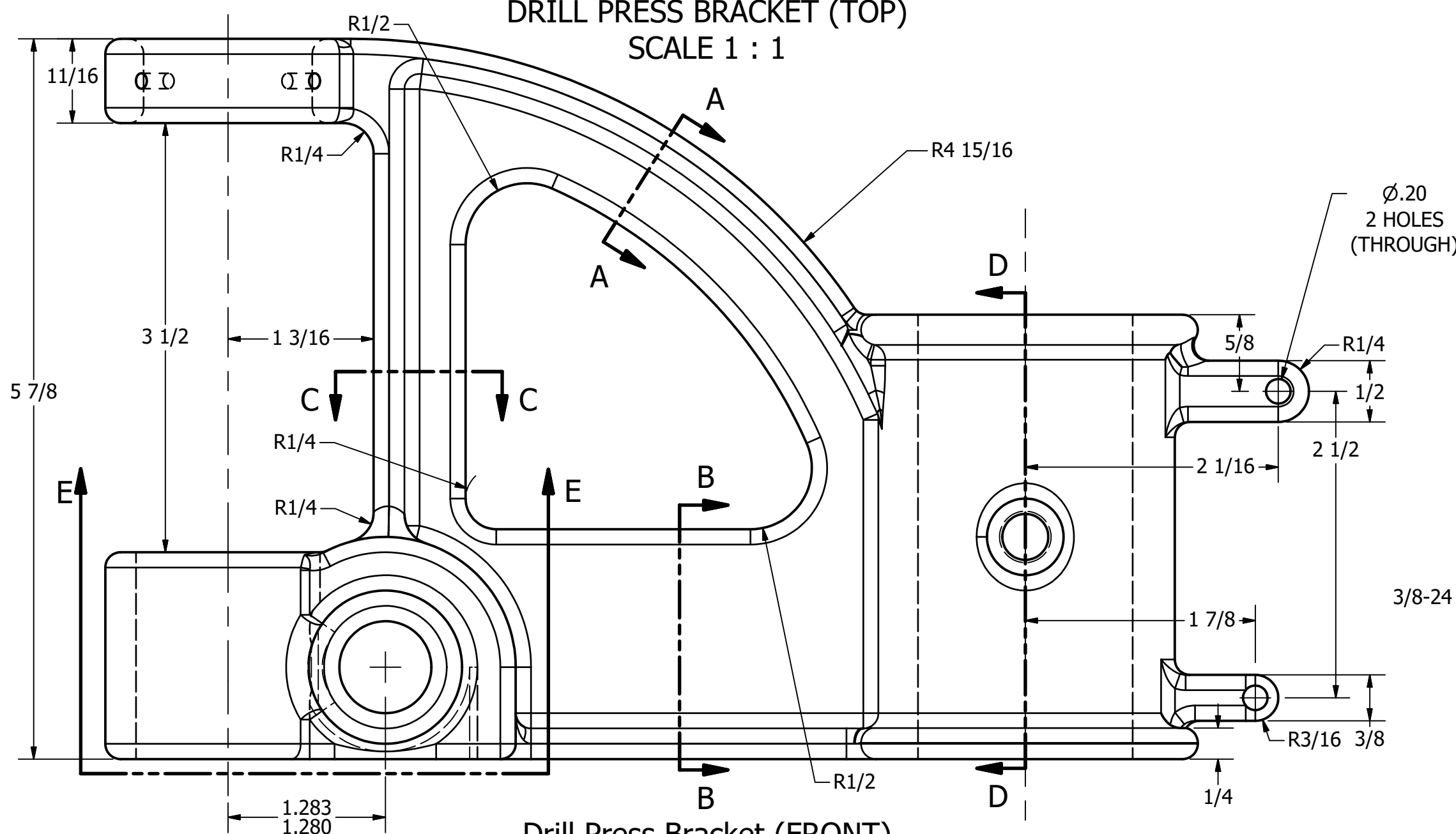

Drill Press Bracket (FRONT)
SCALE 1 : 1

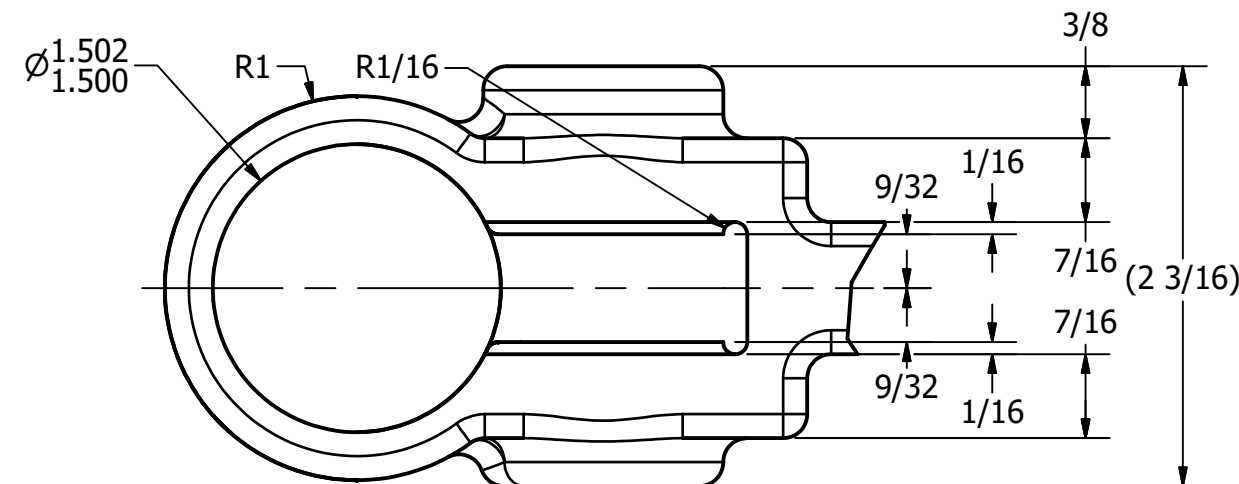

VIEW E-E
SCALE 1 : 1

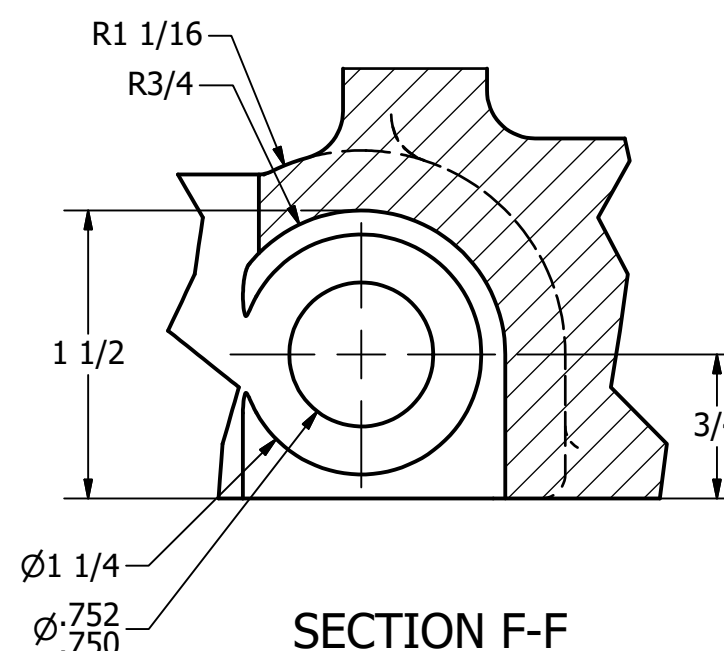

SECTION F-F
SCALE 1 : 1

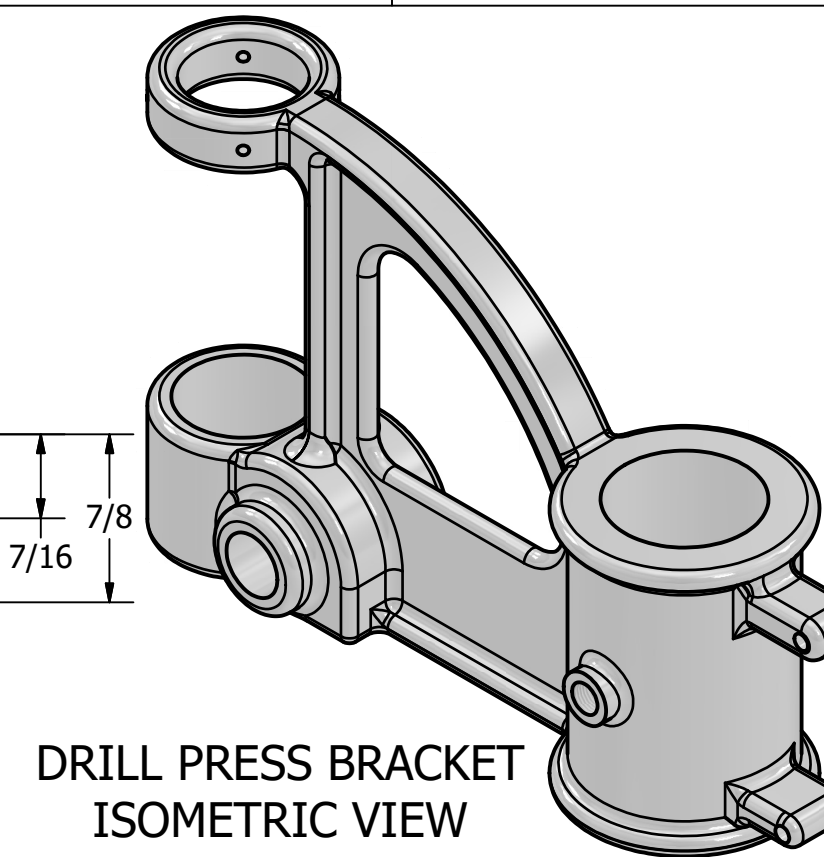

DRILL PRESS BRACKET
ISOMETRIC VIEW
SCALE 1 / 2

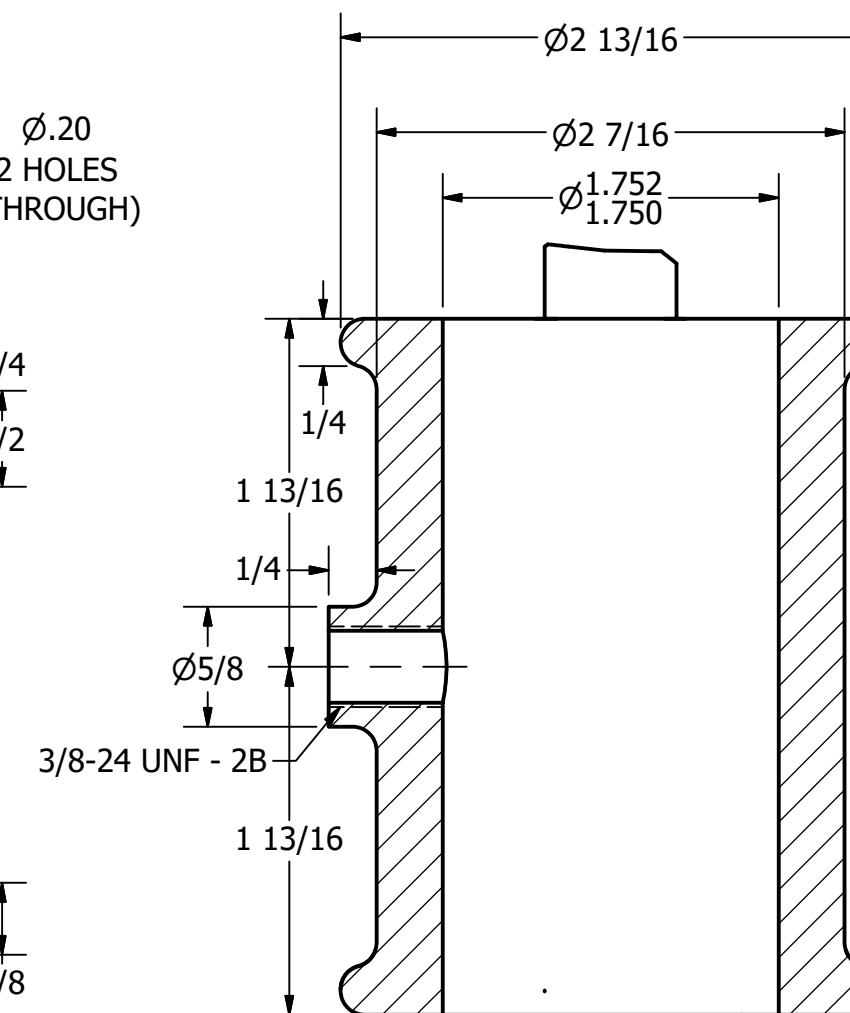

SECTION D-D
SCALE 1 : 1

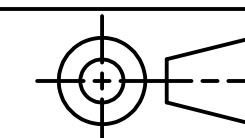

TOLERANCES UNLESS SPECIFIED:
DECIMAL INCHES:
X = ±.020
XX = ±.010
XXX = ±.005
FRACTIONAL ±1/64"
ANGLES ±1 DEGREE
SURFACES 32

CLASS: DDGT 121

ASSIGNMENT #: 36

INVENTOR DRAWING NAME:
DRILL PRESS BRACKET

FIG #: 14-35

MANAGER: G. STROMMEN

DRAFTER: J. JORDAN

DATE: 3/1/2026

SCALE: AS NOTED

PAGE #: 1 OF 1

LEGEND:

Ø DIAMETER
R RADIUS